

2021

CAT® ATTACHMENTS

# BACKHOE LOADERS





## ATTACHMENT HANDBOOK INDEX



<b>BACKHOE BUCKET PINS</b> .....	4
<b>QUICK DISCONNECTS</b> .....	4
<b>HOOK GROUPS-BLANK</b> .....	4
<b>AUGER DRIVE ASSEMBLIES</b> .....	5
<b>AUGER ACCESSORIES</b> .....	5
<b>AUGER BITS</b> .....	6
STANDARD DUTY .....	6
BOLT-ON ROCK HEAD .....	7
INDUSTRIAL .....	7
INDUSTRIAL ROCK .....	8
TREE .....	9
ADAPTERS AND EXTENSIONS .....	9
<b>BUCKETS - LOADER - PIN ON</b> .....	10
GENERAL PURPOSE - SINGLE TILT .....	10
GENERAL PURPOSE - PARALLEL LIFT .....	10
MULTI-PURPOSE - SINGLE TILT .....	11
MULTI-PURPOSE - PARALLEL LIFT - FORK READY ..	11
<b>BUCKETS - LOADER - IT COUPLER</b> .....	12
GENERAL PURPOSE .....	12
MULTI-PURPOSE .....	12
SIDE DUMP .....	13
<b>COUPLERS - LOADER</b> .....	14
<b>PALLET FORKS</b> .....	15
PALLET FORK CARRIAGES .....	15
PALLET FORK TINES .....	15
<b>COUPLERS - BACKHOE</b> .....	16
DUAL LOCK™ - MANUAL .....	16
DUAL LOCK - HYDRAULIC .....	16
<b>BUCKETS - BACKHOE - PIN ON</b> .....	17
STANDARD DUTY .....	18
HEAVY DUTY ROCK .....	18
CEMETERY .....	19
CRIBBING .....	19
GRADING .....	19
STANDARD DUTY - UNITEETH .....	20
STANDARD DUTY - UNITEETH (JCB) .....	20
DITCH CLEANING .....	20
DITCH CLEANING (JCB) .....	20



<b>BUCKETS - BACKHOE - PIN ON - (CONT.)</b> .....	21	<b>HAMMERS</b> .....	30
HIGH CAPACITY.....	21	B MODELS.....	30
HEAVY DUTY.....	21	SIDE MOUNT.....	31
HEAVY DUTY - UNITEETH.....	21	H MODELS.....	33
<b>BACKHOE BUCKETS - G.E.T.</b> .....	22	HAMMERS - TOOLS.....	34
<b>BROOMS</b> .....	24	BRACKETS.....	35
ANGLE BROOMS.....	24	HYDRAULIC LINES.....	35
PICKUP BROOMS.....	25	BRACKET PINS.....	35
<b>MATERIAL HANDLING</b> .....	26	<b>COLD PLANERS</b> .....	36
MATERIAL HANDLING ARMS.....	26	<b>COMPACTION WHEELS</b> .....	37
TRUSS BOOMS.....	26	PIN ON.....	37
LIFTING HOOKS.....	26	<b>RIPPERS</b> .....	38
<b>SNOW PLOWS</b> .....	27	<b>VIBRATORY PLATE COMPACTORS</b> .....	38
<b>SNOW PUSHES</b> .....	28	BRACKETS.....	39
IT COUPLER.....	28	BACKFILL BLADES.....	39
BUCKET RECEIVER.....	29	SWIVEL HEADS.....	39



# BACKHOE LOADER ATTACHMENTS

2021



## BACKHOE BUCKET PINS - SPARE

Pins, BHL-F (45 mm/50 mm) (415-444)	178-3593
Price	\$
Pins, BHL-F (60 mm/60 mm) (450)	556-3635
Price	\$

F2 backhoe loaders (and newer) quick disconnects have changed to “Twist to Connect”. F1 and earlier models have “Push to Connect”. If you have auxiliary on the front these are the correct Quick Disconnects:



**TWIST TO CONNECT**

COUPLINGS QUICK DISCONNECT		LOADER	
	Kit (Includes male and female)	Male	Female
Twist to Connect	455-7380	439-1589	439-1588
Price	\$	\$	\$
Push to Connect	N/A	195-6525	421-6170
Price		\$	\$



**PUSH TO CONNECT**

COUPLINGS QUICK DISCONNECT		BACKHOE	
	Kit (Includes male and female)	Male	Female
Twist to Connect	442-9566	439-1591	439-1590
Price	\$	\$	\$
Push to Connect	N/A	106-0406	106-0401
Price		\$	\$



Hook, Blank, IT  
109-6712



Hook, Blank, IT (Flat Back)  
113-2677

# BACKHOE LOADER ATTACHMENTS

## 2021

Cat® augers offer different speed and torque options for work in a variety of soils. The speed and torque are engineered to extract soil efficiently and prevent stalling in dense ground. Select from a range of auger bits.



**AUGERS**

<b>AUGER DRIVE ASSEMBLIES (INCLUDES BRACKET)</b>	
<b>MODEL - Legacy</b>	<b>A26B</b>
<b>MODEL - Current</b>	<b>A68</b>
Machine	415-444
Interface	Pin On
Overall Height - in (mm)	40 (1006)
Weight - lb (kg)	403 (183)
Drive Shaft Torque at Max Pressure - lb/ft (N•m)	5038 (6830)
Required Hydraulics	Rear Aux
Drive Method	Double Planetary
Part Number	227-4359
Price	\$



**AUGER DRIVE - A68**



**BRACKET - PIN ON**



**BRACKET - 1/4 YD PIN LOCK**

### **AUGER ACCESSORIES**

Auger Drive - A68	225-8809	\$
Bracket - Pin On (415-444)	227-4350	\$
Lines Group (415-444)	227-4358	\$

# BACKHOE LOADER ATTACHMENTS

2021

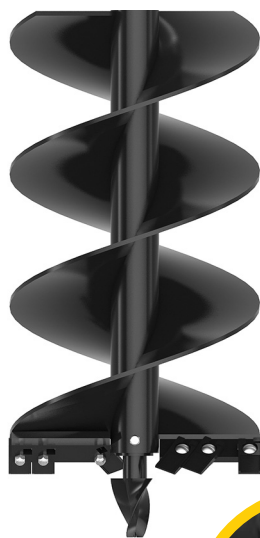

**AUGER BIT - STANDARD DUTY**

## AUGER BITS - STANDARD DUTY

Diameter - in (mm)	4 (102)	6 (152)	9 (229)	12 (305)	15 (381)
Overall Length - in (mm)	48 (1219)	49 (1238)	49 (1238)	50 (1279)	51 (1289)
Weight - lb (kg)	40 (18)	51 (23)	75 (34)	101 (46)	111 (50)
Number of Teeth	pilot only	2	3	4	5
Part Number	366-7751	153-4083	153-4084	153-4085	366-7752
Price	\$	\$	\$	\$	\$

## AUGER BITS - STANDARD DUTY (CONT.)

Diameter - in (mm)	18 (457)	24 (610)	30 (762)	36 (914)
Overall Length - in (mm)	50 (1279)	51 (1289)	50 (1279)	50 (1279)
Weight - lb (kg)	143 (65)	203 (92)	282 (128)	381 (173)
Number of Teeth	6	8	10	12
Part Number	153-4086	153-4089	217-3194	153-4091
Price	\$	\$	\$	\$

# BACKHOE LOADER ATTACHMENTS

## 2021



**AUGER - BOLT-ON  
ROCK HEAD**

### AUGER BITS - BOLT-ON ROCK HEAD

Diameter - in (mm)	6 (191)	9 (267)	12 (343)	15 (419)	18 (495)	24 (648)
Overall Length - in (mm)	9 (238)	10 (251)	10 (251)	10 (263)	11 (276)	12 (302)
Weight - lb (kg)	23 (11)	33 (15)	41 (19)	47 (21)	55 (25)	79 (36)
Number of Teeth	8	10	12	14	16	20
Part Number	372-0230	372-0231	372-0232	372-0233	372-0234	372-0235
Price	\$	\$	\$	\$	\$	\$

- Requires standard flight
- Transforms a standard bit into an rock drill bit
- For severe ground conditions including rock and various types of concrete
- Bolt-on design for easy removal when returning to normal conditions



**AUGER - INDUSTRIAL**

### AUGER BITS - INDUSTRIAL

Diameter - in (mm)	6 (152)	9 (229)	12 (305)	16 (407)	18 (457)
Overall Length - in (mm)	48 (1224)	48 (1220)	48 (1219)	48 (1221)	48 (1224)
Weight - lb (kg)	57 (26)	73 (33)	90 (41)	115 (52)	108 (49)
Number of Teeth	2	4	4	6	6
Part Number	372-0260	372-0261	372-0262	372-0263	372-0264
Price	\$	\$	\$	\$	\$

### AUGER BITS - INDUSTRIAL (CONT.)

Diameter - in (mm)	24 (610)	30 (762)	36 (914)	42 (1067)	48 (1219)
Overall Length - in (mm)	48 (1219)	48 (1219)	48 (1219)	48 (1219)	48 (1220)
Weight - lb (kg)	150 (68)	181 (82)	223 (101)	291 (132)	344 (156)
Number of Teeth	8	12	12	16	16
Part Number	372-0265	372-0266	372-0267	372-0268	372-0269
Price	\$	\$	\$	\$	\$



### AUGER - INDUSTRIAL ROCK

<b>AUGER BITS - INDUSTRIAL ROCK</b>					
Diameter - in (mm)	6 (152)	9 (229)	12 (305)	16 (406 )	18 (457)
Overall Length - in (mm)	48 (1222)	48 (1222)	48 (1222)	48 (1221)	48 (1221)
Weight - lb (kg)	79 (36)	108 (49)	135 (61)	168 (76)	192 (87)
Number of Teeth	8	10	12	15	16
Part Number	372-0270	372-0271	372-0272	372-0273	372-0274
Price	\$	\$	\$	\$	\$

<b>AUGER BITS - INDUSTRIAL ROCK (CONT.)</b>				
Diameter - in (mm)	20 (508)	24 (610)	30 (762 )	36 (914)
Overall Length - in (mm)	48 (1221)	48 (1222)	48 (1222)	48 (1222)
Weight - lb (kg)	218 (99)	282 (128)	311 (141)	410 (186)
Number of Teeth	17	20	24	26
Part Number	372-0275	372-0276	372-0277	372-0278
Price	\$	\$	\$	\$

- Excellent tooth retention while digging
- Allows for easy removal and installation



# BACKHOE LOADER ATTACHMENTS

## 2021



Tree bits have a tapered tip for drilling holes with a large mouth and narrow base to properly fit a root ball or holes with a small diameter to fill with mulch or fertilizer.



**AUGER - TREE**

### AUGER BITS - TREE

Upper Diameter - in (mm)	24 (610)	36 (914)
Lower Diameter - in (mm)	12 (305)	18 (457)
Overall Length - in (mm)	51 (1289)	51 (1288)
Weight - lb (kg)	163 (74)	309 (140)
Number of Teeth	5	7
Part Number	153-4092	153-4095
Price	\$	\$



**RETENTION PIN KIT  
372-0258**

### ADAPTERS AND EXTENSIONS

Adapter, Hex - 2 in (50 mm) to Round - 2 9/16 in (65 mm)	156-6329	\$
Adapter, Round 2 9/16 in (65 mm) to Hex 2 in (50 mm)	217-3191	\$
Extension, Telescoping 3 ft (914 mm)	372-0256	\$
Extension, Telescoping 6 ft (1829 mm)	372-0257	\$
Extension, Auger 12 in (305 mm)	156-6328	\$
Extension, Auger 24 in (610 mm)	217-3192	\$
Retention Pin Kit	372-0258	\$



**EXTENSION - TELESCOPING  
372-0256  
3 ft (914 mm)**

3 adjustments spaced 1 ft (305 mm) apart

**EXTENSION  
156-6328  
12 in (305 mm)**



**ADAPTER  
217-3191  
ROUND TO HEX**



**EXTENSION - TELESCOPING  
372-0257  
6 ft (1829 mm)**

6 adjustments spaced 1 ft (305 mm) apart

**EXTENSION  
217-3192  
24 in (610 mm)**

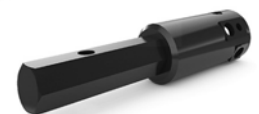

**ADAPTER  
156-6329  
HEX TO ROUND**



# BACKHOE LOADER ATTACHMENTS

## 2021

The shape of Cat loader buckets was designed to improve digging, loading and material retention. Each bucket is made of high-strength, tempered steel. Select from a range of bucket teeth.



SINGLE TILT GENERAL PURPOSE BUCKET BASE EDGE		PIN ON
Capacity - yd3 (m3)	1 (0.76)	1.3 (1)
Compatibility	415-444	415-444
Width - in (mm)	89 (2262)	89 (2262)
Height - in (mm)	30 (758)	33 (843)
Length - in (mm)	34 (852)	38 (965)
Weight - lb (kg)	776 (352)	965 (438)
Part Number	337-7392	430-6767
Price	\$	\$



PARALLEL LIFT GENERAL PURPOSE BUCKET BASE EDGE (NON-EST)*		PIN ON
Capacity - yd3 (m3)	1.3 (1.0)	1.25 (0.95)
Compatibility	426F2, 427F2, 428F/F2 ST, 432F/F2	
Width - in (mm)	95 (2406)	89 (2262)
Height - in (mm)	33 (839)	33 (839)
Length - in (mm)	35 (880)	35 (880)
Weight - lb (kg)	968 (439)	1129 (512)
Heavy Duty	No	Yes
Part Number	337-7394	430-6772
Price	\$	\$



PARALLEL LIFT GENERAL PURPOSE BUCKET BASE EDGE (EST)*		PIN ON
Capacity - yd3 (m3)	1.5 (1.15)	1.7 (1.3)
Compatibility	434F/F2 ST, 444F/F2	
Width - in (mm)	96 (2434)	96 (2434)
Height - in (mm)	35.5 (901)	39 (997)
Length - in (mm)	37 (942)	37 (942)
Weight - lb (kg)	959 (435)	1012 (459)
Part Number	337-7400	337-7408
Price	\$	\$

\* EST = Equal size tires / NON-EST = Non-equal size tires

# BACKHOE LOADER ATTACHMENTS

2021



SINGLE TILT MULTI-PURPOSE BUCKET		PIN ON
Capacity - yd3 (m3)		1.35 (1.03)
Compatibility		415-444
Width - in (mm)		95 (2406)
Height - in (mm)		39 (985)
Length- in (mm)		35 (900)
Weight - lb (kg)		1593 (723)
Part Number		337-7418
Price		\$



PARALLEL LIFT MULTI-PURPOSE BUCKET BASE EDGE (NON-EST)*		PIN ON
Capacity - yd3 (m3)		1.35 (1.03)
Compatibility		426F2, 427F2, 428F/F2 ST, 432F/F2
Width - in (mm)		95 (2417)
Height - in (mm)		41 (1037)
Length- in (mm)		35 (892)
Weight - lb (kg)		1510 (685)
Part Number		350-1581
Price		\$
Kit, Forks Brackets, Fold Over**		559-4077
Price		\$
Forks (Requires 2)		452-7707
Price		\$

\*\* Requires quantity 2 of 452-7707 Forks



\* EST = Equal size tires / NON-EST = Non-equal size tires





# BACKHOE LOADER ATTACHMENTS

2021



## PARALLEL LIFT MULTI-PURPOSE BUCKET BASE EDGE (EST)\*

**PIN ON**

Capacity - yd3 (m3)	1.5 (1.15)	1.7 (1.3)
Compatibility	434F/F2 and 444F/F2	
Width - in (mm)	96 (2434)	96 (2434)
Height - in (mm)	42 (1075)	42 (1070)
Length- in (mm)	37 (944)	39 (997)
Weight - lb (kg)	1700 (771)	2022 (917)
Part Number	536-0021	536-0028
Price	\$	\$
Kit, Forks Brackets, Fold Over**	539-6958	N/A
Price	\$	
Kit, Forks Brackets, Fold Over**	N/A	539-6959
Price		\$
Forks (Requires 2)	452-7707	452-7707
Price	\$	\$

\*\* Requires quantity 2 of 452-7707 Forks



## GENERAL PURPOSE BUCKETS - BASE EDGE

**IT**

Capacity - yd3 (m3)	1.5 (1.15)
Compatibility	415-444
Width - in (mm)	96 (2434)
Height - in (mm)	39.2 (997)
Length - in (mm)	37.6 (955)
Weight - lb (kg)	1067 (484)
Part Number	248-0962
Price	\$



## MULTI-PURPOSE BUCKETS - BASE EDGE

**IT**

Capacity - yd3 (m3)	1.35 (1.03)	1.7 (1.3)
Compatibility	415-444	415-444
Width - in (mm)	95 (2406)	96 (2434)
Height - in (mm)	38.3 (973)	39.2 (996)
Length - in (mm)	34.4 (875)	39.5 (1003)
Weight - lb (kg)	1151 (522)	1102 (500)
Part Number	318-7267	320-9940
Price	\$	\$

\* EST = Equal size tires / NON-EST = Non-equal size tires

# BACKHOE LOADER ATTACHMENTS

2021

Cat side dump buckets are capable of dumping forward or to the left side and provide the versatility required in tight work areas and congested environments. The side dump bucket is designed for loading, carrying, leveling, back-filling and dumping in a variety of applications and materials.



**SIDE DUMP BUCKET**

<b>SIDE DUMP BUCKET BOLT-ON CUTTING EDGE</b>		<b>IT</b>
Capacity - yd3 (m3)	1.25 (0.95)	
Width - in (mm)	109 (2770)	
Height - in (mm)	45 (1154)	
Length - in (mm)	39 (995)	
Weight - lb (kg)	2178 (988)	
Part Number	571-8458	
Price	\$	

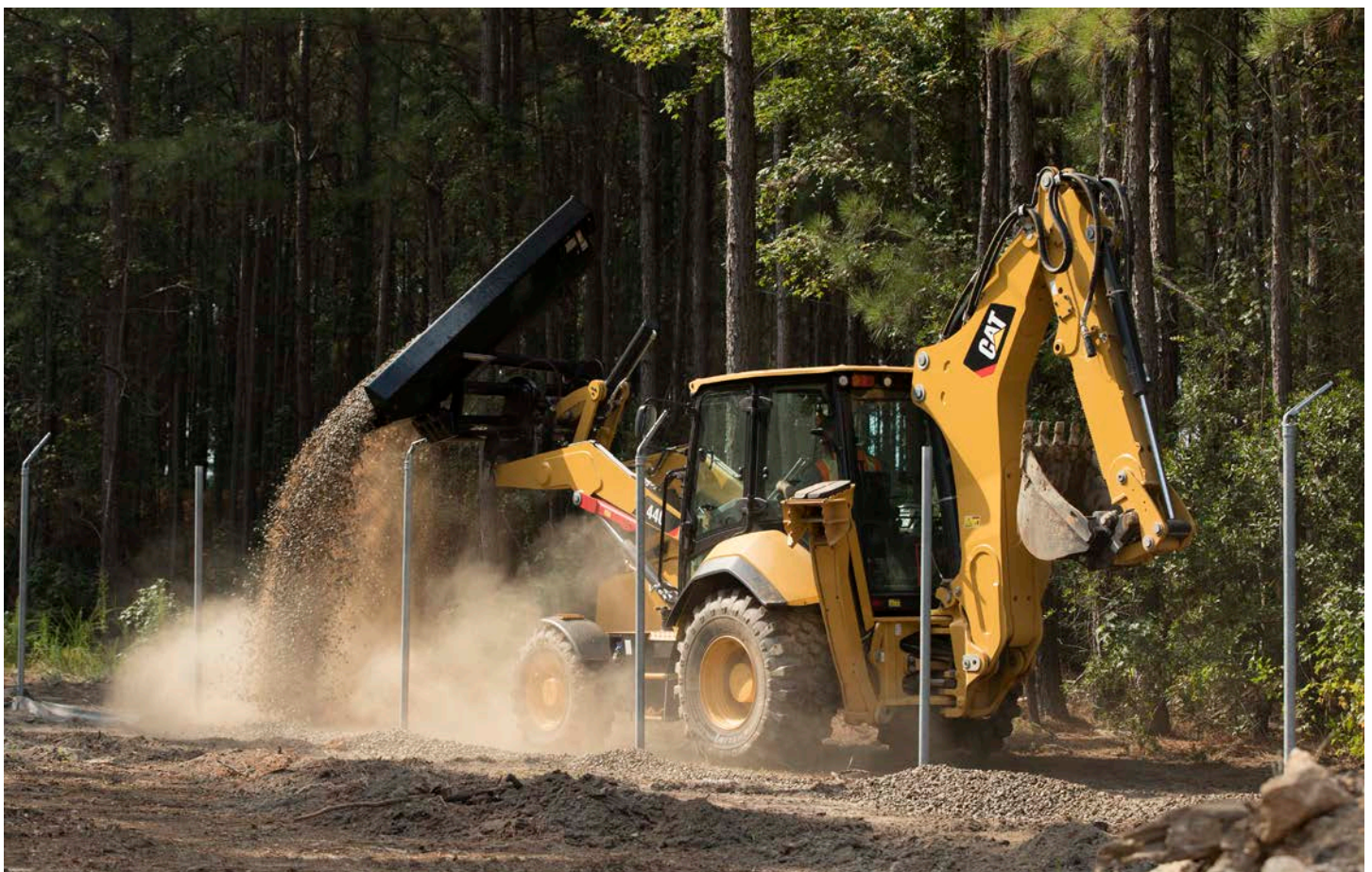

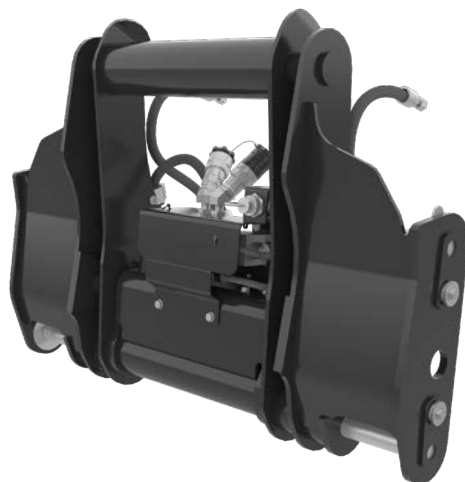

LOADER COUPLERS		IT
Machine	432F/F2, 426F2, 428F/F2	444F/F2, 434F/F2
Weight - lb (kg)	461 (209)	497 (226)
Required Hydraulics	3rd Valve	3rd Valve
Part Number	472-4303	472-4304
Price	\$	\$



# BACKHOE LOADER ATTACHMENTS

## 2021

Cat pallet forks are designed to meet a wide variety of material handling needs. Use pallet forks for moving bulky or palletized materials on construction and industrial sites, handling bagged fertilizer and seed at landscaping and nursery sites.



**PALLET FORKS**

### PALLET FORKS

Tine Length - in (mm)	48 (1220)	48 (1220)
Carriage Height - in (mm)	28 (699)	40 (1010)
Carriage Width - in (mm)	60 (1524)	75 (1900)
Tine Width - in (mm)	5 (127)	5 (125)
Tine Thickness - in (mm)	2 (51)	2.4 (60)
Operating Weight - lb (kg)	1007 (456)	1192 (541)
Overall Length - in (mm)	67 (1698)	64 (1618)
Max Tine Spacing (center to center)- in (mm)	58 (1471)	75 (1900)
Interface	Pin on (ST)	IT
Hydraulic Adjustment	No	Yes
Part Number	461-0763	573-4593
Price	\$	\$



### PALLET FORK CARRIAGES

Length - in (mm)	14 (356)
Width - in (mm)	61 (1550)
Height - in (mm)	36 (914)
Weight - lb (kg)	588 (267)
Max Tine Spacing (center to center) - in (mm)	52 (1320)
Part Number	6W-8832
Price	\$



### FORK TINES

Tine Length - in (mm)	41.3 (1050)	47.2 (1200)	53.2 (1350)
Overall Length - in (mm)	44.9 (1140)	50.8 (1290)	56.7 (1440)
Width - in (mm)	5 (130)	5 (130)	5 (130)
Height - in (mm)	31.5 (800)	31.5 (800)	31.5 (800)
Weight - lb (kg)	183 (83)	201 (91)	216 (98)
Part Number	6W-8933	6W-8900	6W-9739
Price	\$	\$	\$

### BACKHOE COUPLERS



**DUAL LOCK™ PIN  
GRABBER - MANUAL**



**DUAL LOCK PIN  
GRABBER - HYDRAULIC**

#### BACKHOE COUPLERS

415-444

Machine	415-444	415-444
Coupler Type	Dual Lock Pin Grabber	Dual Lock Pin Grabber
Weight - lb (kg)	192 (87)	201 (91)
Manual or Hydraulic	Manual	Hydraulic
Part Number	444-7500	485-5303
Price	\$	\$
Bucket Pins - 45-50mm	178-3593	178-3593
Price	\$	\$

#### HYDRAULIC KITS-DUAL LOCK PIN GRABBER COUPLERS

415-444

Machine	Side Shift 14 ft	Side Shift 14 ft	Side Shift 16 ft
Stick Type	Standard Stick	Extended Stick	Extended Stick
Part Number	379-6431	371-5682	379-5292
Price	\$	\$	\$

# BACKHOE LOADER ATTACHMENTS

## 2021

### BACKHOE BUCKETS

Caterpillar offers ten types of backhoe buckets for Cat backhoe loaders. While they share many common features, each is designed to perform certain specific tasks. All buckets are pin on unless a pin lock option is available.

#### **Cemetery Buckets**

- Offers the ability to dig trenches with vertical walls and flat bottom due to the special design. This type of bucket is used to trench graves and other applications that require this trench profile, such as tanks and swimming pools.

#### **Coral Buckets**

- Available in four widths and are designed especially for rocky coral conditions such as those found on coastlines.

#### **Cribbing Buckets**

- Designed with a very narrow profile offering the capability to clean and maintain in between and under railroad ties. Ideal for light trenching on moderate abrasive soils.

#### **Ditch Cleaning Buckets**

- Available in three widths designed to provide optimum trenching, slope-cutting, grading and finishing work.

#### **Grading Buckets**

- Available in two widths and are designed to provide optimum grading, trenching, slope-cutting and finishing work in addition to nesting additional buckets for ease of transportation.

#### **Heavy Duty Buckets**

- Available in six widths (pin on and pin lock), all with standard Diagonal Retention System adapters and teeth. They are especially well suited for semi-rocky soil or where hard bank material must be broken out and removed.

#### **Heavy Duty Rock Buckets**

- Available in five widths, all with standard Diagonal Retention System adapters and teeth. They are specifically designed to work in the harsh rocky conditions found in various regions of the world.

#### **High Capacity Buckets**

- Available in four pin-on widths and are especially well suited for work in lower density soils and light materials. They have the same durable characteristics as heavy duty buckets but are capable of moving greater volumes.

#### **Soil Excavation Buckets**

- Available in four widths, they have heavy duty characteristics with higher capacity, for use in a variety of conditions including heavy impact. The more aggressive adapter nose angle combined with the new tip design provides enhanced productivity in all soils, plus longer wear and sharpness in rocky areas.

#### **Standard Duty Buckets**

- Available in five widths, all with standard Diagonal Retention System adapters and teeth. They are designed for general light duty excavation in soft soil or clay.



# BACKHOE LOADER ATTACHMENTS

2021



**STANDARD DUTY BUCKET**

<b>STANDARD DUTY BUCKETS - 415-444</b>					<b>PIN ON</b>
Width - in (mm)	12 (305)	18 (457)	24 (610)	30 (762)	36 (914)
Capacity - ft <sup>3</sup> (L)	2.8 (79)	4.2 (119)	6.2 (176)	8.2 (232)	10.3 (292)
Weight - lb (kg)	214 (97)	254 (115)	292 (132)	325 (147)	364 (165)
Number of Teeth	3	4	5	5	6
Part Number	219-3410	219-3380	219-3381	219-3382	219-3383
Price	\$	\$	\$	\$	\$



**HEAVY DUTY ROCK BUCKET**

<b>HEAVY DUTY ROCK BUCKETS - 415-444</b>					<b>PIN ON</b>
Width - in (mm)	12 (305)	18 (457)	24 (610)	30 (762)	36 (914)
Capacity - ft <sup>3</sup> (L)	3 (71)	5 (130)	7 (198)	9 (269)	11 (325)
Weight - lb (kg)	250 (113)	305 (138)	382 (173)	397 (180)	452 (205)
Number of Teeth	3	4	5	5	6
Part Number	219-3412	219-3395	219-3396	219-3397	219-3398
Price	\$	\$	\$	\$	\$

# BACKHOE LOADER ATTACHMENTS

2021



**CEMETERY BUCKET**

<b>CEMETERY BUCKETS - 415-444</b>		<b>PIN ON</b>
Width - in (mm)	26 (914)	26 (914)
Capacity - ft <sup>3</sup> (L)	8.5 (240)	8.5 (240)
Weight - lb (kg)	520 (236)	485 (220)
Number of Teeth/Edge Type	5	Cutting Edge
Part Number	242-5039	219-8655
Price	\$	\$



**CRIBBING BUCKET**

<b>CRIBBING BUCKETS - 415-444</b>		<b>PIN ON</b>	
Width - in (mm)	8 (203)	9 (230)	9 (230)
Capacity - ft <sup>3</sup> (L)	1.4 (40)	2.1 (60)	2.1 (60)
Weight - lb (kg)	289 (131)	319 (145)	315 (143)
Number of Teeth	2	2	2
Part Number	226-5743	216-3294	216-3295*
Price	\$	\$	\$

\* JCB Bucket



**GRADING BUCKET**

<b>GRADING / MUD BUCKET - 415-444</b>		<b>PIN ON</b>	
Width - in (mm)	47 (1200)	59 (1500)	
Capacity - ft <sup>3</sup> (L)	14.5 (410)	18.4 (520)	
Weight - lb (kg)	633 (287)	744 (338)	
Edge Type	Cutting Edge	Cutting Edge	
Includes Pins?	Yes	Yes	
Part Number	388-9668	388-9669	
Price	\$	\$	

# BACKHOE LOADER ATTACHMENTS

2021



**STANDARD DUTY BUCKET - UNITEETH**

STANDARD DUTY BUCKETS - UNITEETH - 415-444					PIN ON
Width - in (mm)	12 (305)	18 (457)	24 (610)	30 (762)	36 (914)
Capacity - ft <sup>3</sup> (L)	2.8 (79)	4.2 (119)	6.2 (176)	8.2 (232)	10.3 (292)
Weight - lb (kg)	229 (104)	255 (116)	308 (140)	360 (163)	385 (175)
Number of Teeth	3	3	4	5	6
Part Number	273-3791	273-1374	273-1948	273-1950	273-1957
Price	\$	\$	\$	\$	\$

STANDARD DUTY BUCKETS - UNITEETH - 415-444 (JCB)					PIN ON
Width - in (mm)	12 (305)	18 (458)	24 (610)	30 (762)	36 (915)
Capacity - ft <sup>3</sup> (L)	2.1 (60)	4.2 (120)	6.4 (180)	8.1 (230)	10.2 (290)
Weight - lb (kg)	236 (107)	265 (120)	307 (139)	353 (160)	390 (177)
Number of Teeth	3	3	4	5	6
Part Number	200-2193	200-2194	200-2195	200-2196	200-2197
Price	\$	\$	\$	\$	\$



**DITCH CLEANING BUCKET**

DITCH CLEANING BUCKETS - 415-444					PIN ON
Width - in (mm)	47 (1200)	55 (1400)	59 (1500)	63 (1600)	71 (1800)
Capacity - ft <sup>3</sup> (L)	7.8 (220)	9.2 (260)	10.2 (290)	10.9 (310)	12.4 (350)
Weight - lb (kg)	271 (123)	302 (137)	319 (145)	335 (152)	365 (166)
Edge Type	Base Edge	Base Edge	Base Edge	Base Edge	Base Edge
Part Number	192-0657	192-0658	191-9555	192-0660	192-0661
Price	\$	\$	\$	\$	\$

DITCH CLEANING BUCKETS - 415-444 - (JCB)					PIN ON
Width - in (mm)	47 (1200)	55 (1400)	59 (1500)	63 (1600)	71 (1800)
Capacity - ft <sup>3</sup> (L)	7.8 (220)	9.2 (260)	10.2 (290)	10.9 (310)	12.4 (350)
Weight - lb (kg)	271 (123)	304 (138)	320 (145)	335 (152)	365 (166)
Edge Type	Base Edge	Base Edge	Base Edge	Base Edge	Base Edge
Part Number	191-6261	192-2825	191-6262	192-2826	191-6263
Price	\$	\$	\$	\$	\$



# BACKHOE LOADER ATTACHMENTS

## 2021



**HIGH CAPACITY BUCKET  
UNITEETH**

### HIGH CAPACITY HEAVY DUTY BUCKETS - UNITEETH - PIN ON 415-444

	18 (457)	24 (610)	30 (762)	36 (914)
Width - in (mm)	18 (457)	24 (610)	30 (762)	36 (914)
Capacity - ft <sup>3</sup> (L)	6.4 (180)	8.5 (240)	11.3 (320)	13.4 (380)
Weight - lb (kg)	328 (149)	366 (166)	421 (191)	452 (205)
Number of Teeth	3	4	5	6
Part Number	151-7887	151-7888	151-7889	151-7890
Price	\$	\$	\$	\$

### HEAVY DUTY BUCKETS - PIN ON TEETH - 415-444

	12 (305)	16 (407)	16 (407)	18 (457)	24 (610)	30 (762)	31.5 (800)	36 (914)
Width - in (mm)	12 (305)	16 (407)	16 (407)	18 (457)	24 (610)	30 (762)	31.5 (800)	36 (914)
Capacity - ft <sup>3</sup> (L)	3 (79)	2.8 (68)	4 (105)	4.3 (122)	6.5 (176)	8 (232)	242 (8.8)	10 (292)
Weight - lb (kg)	216 (98)	192 (87)	271 (123)	287 (130)	365 (166)	375 (170)	385 (175)	403 (183)
Number of Teeth	3	3	4	4	5	5	5	6
Part Number	273-3701	319-8978	273-0093	272-6410	249-4221	272-7872	272-9219	272-9234
Price	\$	\$	\$	\$	\$	\$	\$	\$

**HEAVY DUTY BUCKET  
PIN ON TEETH**



**HEAVY DUTY BUCKET  
UNITEETH**



### HEAVY DUTY BUCKETS - UNITEETH - 415-444

	12 (305)	12 (305)	18 (457)	24 (610)	24 (610)	30 (762)	36 (914)
Width - in (mm)	12 (305)	12 (305)	18 (457)	24 (610)	24 (610)	30 (762)	36 (914)
Capacity - ft <sup>3</sup> (L)	3 (79)	2.8 (68)	4.2 (118)	6.4 (175)	6.2 (180)	8.1 (233)	10 (292)
Weight - lb (kg)	212 (96)	212 (96)	275 (125)	309 (140)	320 (145)	384 (174)	454 (206)
Number of Teeth	3	3	3	4	4	5	6
Part Number	273-3731	273-5541	273-0862	273-0799	508-2488	273-0042	272-9608
Price	\$	\$	\$	\$	\$	\$	\$

### CAT® BACKHOE GROUND ENGAGING TOOLS (GET)

Made from through-hardened DH-2 steel, both the tips and adapters of the Diagonal Retention System (DRS) deliver optimal strength and resistance to abrasive wear. The DRS features a right-hand drive pin slot at a 40° angle from the previous horizontal system.

BUCKET TEETH - FEATURES AND APPLICATIONS	
<b>Long</b>	<p><b>Attributes:</b></p> <ul style="list-style-type: none"> <li>• Long, symmetric, top and bottom self-sharpening cavities</li> <li>• Good strength, penetration and wear material</li> </ul> <p><b>Applications:</b></p> <ul style="list-style-type: none"> <li>• General excavation and loading</li> <li>• Low to moderate impact and abrasion</li> </ul>
<b>Chisel</b>	<p><b>Attributes:</b></p> <ul style="list-style-type: none"> <li>• Flat bottom design</li> </ul> <p><b>Applications:</b></p> <ul style="list-style-type: none"> <li>• Moderate impact and high abrasion for footing, steam walls or a clean trench floor</li> </ul>
<b>Soil</b>	<p><b>Attributes:</b></p> <ul style="list-style-type: none"> <li>• Through-hardened DH-2 steel fabrication</li> </ul> <p><b>Applications:</b></p> <ul style="list-style-type: none"> <li>• Hard soil jobsites</li> <li>• Non-abrasive, low-impact situations</li> </ul>
<b>Penetration</b>	<p><b>Attributes:</b></p> <ul style="list-style-type: none"> <li>• Leading edge with 60% less cross-sectional area</li> <li>• Single center rib that self-sharpens during wear</li> </ul> <p><b>Applications:</b></p> <ul style="list-style-type: none"> <li>• Densely-compacted materials</li> </ul>
<b>Wide</b>	<p><b>Attributes:</b></p> <ul style="list-style-type: none"> <li>• Flat bottom design</li> <li>• Reduced spillage</li> </ul> <p><b>Applications:</b></p> <ul style="list-style-type: none"> <li>• Increased bucket capacity situations</li> <li>• Cohesive materials with minimal penetration needs</li> </ul>
<b>Sharp</b>	<p><b>Attributes:</b></p> <ul style="list-style-type: none"> <li>• Curved shape</li> <li>• Strong and durable</li> </ul> <p><b>Applications:</b></p> <ul style="list-style-type: none"> <li>• Densely-compacted materials</li> </ul>
<b>Sharp - Twin</b>	<p><b>Attributes:</b></p> <ul style="list-style-type: none"> <li>• Curved shape</li> <li>• Very good penetration</li> <li>• Stays sharp</li> </ul> <p><b>Applications:</b></p> <ul style="list-style-type: none"> <li>• Hard-to-penetrate fracturable materials</li> </ul>

# BACKHOE LOADER ATTACHMENTS

2021



**LONG**



**CHISEL**



**PENETRATION**



**WIDE**



**SHARP**



**SHARP-TWIN**



**SOIL**



**PIN**



**RETAINER**

## BUCKET TEETH

	Type	Part Number	Price (each)
Long	DRS230	208-5236	\$
Chisel	DRS230	208-5232	\$
Soil	DRS230	208-5234	\$
Penetration	DRS230	208-5235	\$
Wide	DRS230	208-5240	\$
Sharp	DRS230	208-5239	\$
Sharp - Twin	DRS230	208-5237	\$
Pin - Heavy Duty		253-0230	\$
Retainer		201-1239	\$

# BACKHOE LOADER ATTACHMENTS

2021



<b>ANGLE BROOMS</b>		
<b>MODEL</b>	<b>BA25</b>	<b>BA25</b>
Width - in (mm)	106 (2700)	106 (2700)
Sweeping Width - in (mm)	98.4 (2500)	98.4 (2500)
Brush Diameter - in (mm)	27.5 (700)	27.5 (700)
Brush Material (50% Poly / 50% Wire)	Yes	Yes
Height - in (mm)	51 (1300)	51 (1300)
Length - in (mm)	61 (1500)	61 (1500)
Weight - lb (kg)	1027 (466)	1027 (466)
Angling	Manual	Hydraulic
Includes Hooks	No	No
Includes Water	No	No
Includes Twist-to-Connect Quick Disconnects	No	Yes
Part Number	600-8979	600-8980
Price	\$	\$
Hook Group - IT Coupler	487-8490*	487-8490*
Price	\$	\$
Kit - Electrical Switch (Machine Side)	N/A	177-0893**
Price		\$
Kit - Quick Disconnects (Push-Size 12)	196-4191*	N/A
Price	\$	
Kit - Quick Disconnects (Twist-to-connect)	455-7380*	455-7380*
Price	\$	\$
Kit - Spray (12V)	497-9458#	497-9458#
Price	\$	\$
Kit - Tank, Water (400 liters/105 gallons)	497-9461##	497-9461##
Price	\$	\$

\* Required - Broom Side  
 \*\* Required - Machine Side

# Requires Kit-Tank  
 ## Requires Kit-Spray



# BACKHOE LOADER ATTACHMENTS

2021



## PICKUP BROOM

MODEL	BP25
Width - in (mm)	106 (2680)
Sweeping Width - in (mm)	98.4 (2500)
Brush Diameter - in (mm)	27.5 (700)
Brush Material (50% Poly / 50% Wire)	Yes
Height - in (mm)	58 (1461)
Length - in (mm)	72 (1816)
Weight - lb (kg)	1349 (612)
Required Hydraulics	3rd Function
Includes Hooks	No
Water - 106 gal (400 L) Tank and Sprinklers	Yes
Part Number	487-8483
Price	\$
Hook Group - IT Coupler	487-8490*
Price	\$
Kit - Electrical Switch (Machine Side)	177-0893**
Price	\$

\* Required - Broom Side

\*\* Required - Machine Side

# BACKHOE LOADER ATTACHMENTS

2021

Move pipe, concrete blocks, highway dividers and other construction materials quickly and easily with an extendable material handling arm. Length of the arm is manually adjustable to match load and reach requirements.

## MATERIAL HANDLING ARMS IT

Max Load Rating - lb (kg)	4619 (2095)
Max Horizontal Reach - in (mm)	155.2 (3941)
Extended Length - in (mm)	155 (3937)
Retracted Length - in (mm)	79 (2007)
Number of Adjustments	3
Length Between Adjustments - in (mm)	38.1 (967)
Weight - lb (kg)	449 (990)
Part Number	229-9714
Price	\$



## TRUSS BOOM IT

Max Load Rating - lb (kg)	1102 (500)
Max Horizontal Reach - in (mm)	157.5 (4000)
Weight - lb (kg)	425 (193)
Part Number	169-3945
Price	\$



## LIFTING HOOK IT

Max Load Rating - lb (kg)	11023 (5000)
Max Horizontal Reach - in (mm)	19.7 (500)
Weight - lb (kg)	461 (209)
Part Number	169-6460
Price	\$



# BACKHOE LOADER ATTACHMENTS

2021



## SNOW PLOWS

SNOW PLOWS			IT
MODEL	9 ft (2.7 m)	10 ft (3 m)	12 ft (3.6 m)
Width - in (mm)	108 (2743)	120 (3048)	144 (3658)
Overall Height - in (mm)	41 (1051)	41 (1051)	41 (1051)
Blade Height - in (mm)	35 (888)	35 (888)	35 (888)
Length - in (mm)	55 (1385)	55 (1385)	55 (1385)
Weight - lb (kg)	1885 (855)	1989 (902)	2180 (989)
Required Hydraulics	Front Aux	Front Aux	Front Aux
Part Number	481-3671	481-3672	481-3673
Price	\$	\$	\$



### IT COUPLER - SNOW PUSHES

SNOW PUSHES				IT
MODEL	10 ft (3.05 m)	12 ft (3.66 m)	10 ft (3.05 m)	12 ft (3.66 m)
Working Width - in (mm)	120 (3048)	144 (3658)	120 (3048)	144 (3658)
Overall Width - in (mm)	127 (3220)	151 (3829)	127 (3220)	151 (3829)
Trip Edge Height - in (mm)	5 (137)	5 (137)	5 (137)	5 (137)
Overall Height - in (mm)	38 (975)	38 (975)	38 (975)	38 (975)
Length - in (mm)	51 (1279)	51 (1279)	51 (1279)	51 (1279)
Weight - lb (kg)	1803 (818)	1995 (905)	1803 (818)	4112 (1865)
Trip Edge Type	Steel	Steel	Rubber	Rubber
Part Number	479-8087	479-8091	508-8290	508-8295
Price	\$	\$	\$	\$



# BACKHOE LOADER ATTACHMENTS

## 2021



**BUCKET RECEIVER SNOW PUSHES**

<b>SNOW PUSHES</b>		<b>BUCKET RECEIVER</b>		
<b>MODEL</b>	<b>10 ft (3.05 m)</b>	<b>12 ft (3.66 m)</b>	<b>10 ft (3.05 m)</b>	<b>12 ft (3.66 m)</b>
Working Width - in (mm)	120 (3048)	144 (3658)	120 (3048)	144 (3658)
Overall Width - in (mm)	127 (3220)	151 (3829)	127 (3220)	151 (3829)
Trip Edge Height - in (mm)	5 (137)	5 (137)	5 (137)	8 (194)
Overall Height - in (mm)	38 (975)	38 (975)	38 (975)	43 (1086)
Length - in (mm)	69 (1755)	69 (1755)	69 (1755)	77 (1945)
Weight - lb (kg)	1995 (905)	2185 (991)	4112 (1865)	2787 (1264)
Trip Edge Type	Steel	Steel	Rubber	Rubber
Cutting Edge	482-7618	489-3927	482-1496	489-3929
Trip Edge	Yes	Yes	Yes	Yes
Part Number	479-8088	479-8092	508-8300	508-8305
Price	\$	\$	\$	\$

# BACKHOE LOADER ATTACHMENTS

2021

Cat hammers are high performance breakers, designed for maximum performance on demolition, construction and road work. Check with your local Cat dealer for the mounting bracket and hydraulic lines to match the hammer of choice.

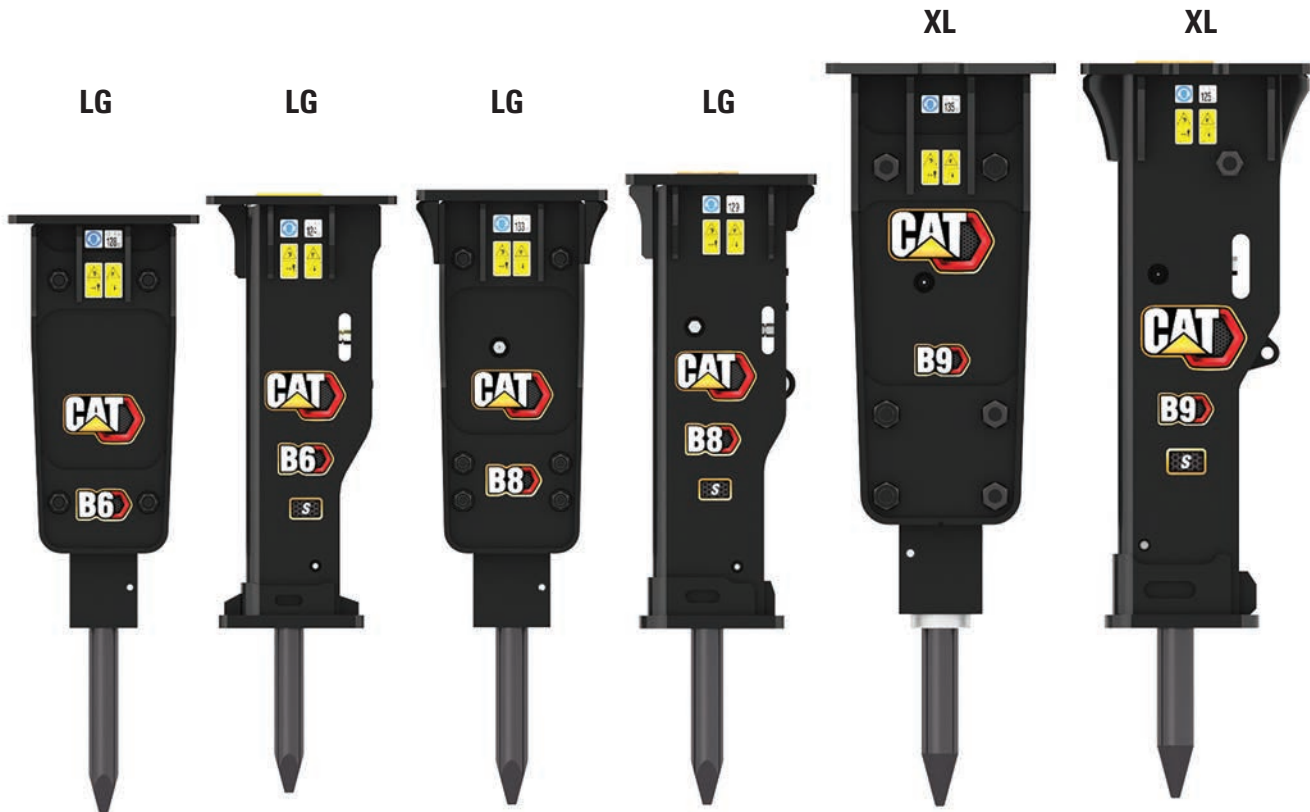

B HAMMERS				TOP MOUNT*
MODEL	B6	B6s	B8	B8s
Height Without Tool - in (mm)	37 (948)	39 (999)	40 (1005)	41 (1050)
Overall Height - in (mm)	56 (1422)	57 (1439)	56 (1412)	56 (1420)
Overall Length - in (mm)	12.4 (316)	12.4 (316)	12 (316)	12 (316)
Overall Width - in (mm)	17 (440)	17 (440)	17 (440)	17 (440)
Tool Shaft Diameter	2.7 (68)	2.7 (68)	3 (75)	3 (75)
Operating Weight - With Tool - lb (kg)	571 (259)	611 (277)	1005 (456)	992 (450)
Minimum Operating Pressure - psi (kPa)	1775 (12238)	1775 (12238)	1704 (11749)	1704 (11749)
Sound - dB	128	124	133	129
Required Hydraulics	Rear Aux	Rear Aux	Rear Aux	Rear Aux
Part Number	532-9106	532-9206	532-9108	532-9208
Price	\$	\$	\$	\$

\*Top Mount Hammers require mounting brackets and lines - see chart on page 35 for more info

# BACKHOE LOADER ATTACHMENTS

## 2021

<b>B HAMMERS (CONT.)</b>		<b>TOP MOUNT*</b>	
<b>MODEL</b>	<b>B9**</b>	<b>B9s**</b>	
Height Without Tool - in (mm)	51 (1298)	51 (1296)	
Overall Height - in (mm)	69 (1753)	68 (1733)	
Overall Length - in (mm)	21 (530)	21 (530)	
Overall Width - in (mm)	16 (400)	16 (400)	
Tool Shaft Diameter	3.4 (85)	3.4 (85)	
Operating Weight - With Tool - lb (kg)	1166 (529)	1142 (518)	
Minimum Operating Pressure - psi (kPa)	1846 (12728)	1846 (12728)	
Sound - dB	135	125	
Required Hydraulics	Rear Aux	Rear Aux	
Part Number	532-9109	532-9209	
Price	\$	\$	

\*\* Not compatible with Side Shift Machines



<b>B HAMMERS</b>		<b>SIDE MOUNT</b>
<b>MODEL</b>	<b>B8</b>	
Compatibility	415-444	
Height Without Tool - in (mm)	44 (1106)	
Overall Height - in (mm)	60 (1514)	
Overall Length - in (mm)	28 (698)	
Overall Width - in (mm)	15 (385)	
Tool Shaft Diameter	3 (75)	
Operating Weight - With Tool - lb (kg)	803 (364)	
Minimum Operating Pressure - psi (kPa)	1704 (11759)	
Sound - dB	133	
Required Hydraulics	Rear Aux	
Part Number	582-1508	
Price	\$	

NOTE: All Cat hammers come with two tools.



# BACKHOE LOADER ATTACHMENTS

2021



**HAMMER TOOL KIT  
INCLUDED WITH  
B HAMMERS**



**HAMMER TOOL KIT  
INCLUDED WITH  
H HAMMERS**

NOTE: All Cat hammers come with two tools.



# BACKHOE LOADER ATTACHMENTS

## 2021



H HAMMERS		TOP MOUNT*		
MODEL	H65s	H80s	H95s**	
Height Without Tool - in (mm)	38 (953)	42 (1057)	49 (1250)	
Overall Height - in (mm)	52 (1324)	56 (1433)	66 (1666)	
Overall Length - in (mm)	18 (451)	21 (535)	21 (520)	
Overall Width - in (mm)	14 (346)	19 (485)	20 (512)	
Tool Shaft Diameter	2.7 (68)	3 (75)	3.5 (88)	
Operating Weight - Without Tool - lb (kg)	534 (242)	725 (329)	1109 (503)	
Minimum Operating Pressure - psi (kPa)	1450 (10000)	1450 (10000)	1450 (10000)	
Maximum Operating Pressure - psi (kPa)	2393 (16500)	2538 (17500)	2495 (17200)	
Minimum Flow - gpm (L/min)	11 (40)	19 (70)	19 (70)	
Maximum Flow - gpm (L/min)	30 (115)	34 (130)	40 (150)	
Sound - dB	124	120	124	
Required Hydraulics	Rear Aux	Rear Aux	Rear Aux	
Part Number	561-2552	561-2553	561-2555	
Price	\$	\$	\$	

\*Top Mount Hammers require mounting brackets and lines - see chart on page 35 for more info

\*\* Not compatible with Side Shift Machines



# BACKHOE LOADER ATTACHMENTS

2021



**MOIL**



**CHISEL - INLINE**



**CHISEL - CROSSCUT**



**CONE**



**BLUNT**



**SPADE - PARALLEL**



**SPADE - TRANSVERSE**



**COMPACTING PLATE**

## HAMMER - TOOLS

Tool	B6	B8	B9	H65	H80	H95
Moil	523-3193	532-9120	532-9219	N/A	N/A	N/A
Price	\$	\$	\$			
Cone	523-3195	532-9118	542-1762	423-8308	369-1548	369-0792
Price	\$	\$	\$	\$	\$	\$
Blunt	523-3196	532-9117	542-1763	423-8309	376-7947	373-7159
Price	\$	\$	\$	\$	\$	\$
Chisel, Inline	523-3191	532-9121	542-1764	423-8307	369-1549	369-0793
Price	\$	\$	\$	\$	\$	\$
Chisel, Crosscut	523-3197	532-9119	542-1765	248-8022	399-1711	399-1710
Price	\$	\$	\$	\$	\$	\$
Moil - Tuck	N/A	566-3424	N/A	N/A	N/A	N/A
Price		\$				
Cone - Tuck	N/A	566-3422	N/A	N/A	N/A	N/A
Price		\$				
Blunt - Tuck	N/A	566-3421	N/A	N/A	N/A	N/A
Price		\$				
Chisel, Inline - Tuck	N/A	566-3425	N/A	N/A	N/A	N/A
Price		\$				
Chisel, Crosscut - Tuck	N/A	566-3423	N/A	N/A	N/A	N/A
Price		\$				
Spade, Parallel	##	##	N/A	433-9653	381-6720	N/A
Price				\$	\$	
Spade, Transverse	##	##	N/A	433-9652	381-6719	N/A
Price				\$	\$	
Compacting Plate	##	##	N/A	433-9651	381-6721	N/A
Price				\$	\$	

## Coming Soon

# BACKHOE LOADER ATTACHMENTS

## 2021



**LG**



**XL**



**TUCK**



Note: B and H Hammer lines are not interchangeable.

### HAMMER BRACKETS

\* Uses LG Brackets \*\* Uses XL Brackets

MODEL	B6*	B8*	B9**	H65s*	H80s**	H95s**
Bracket 45 mm/50 mm, Pin On	567-9320	567-9320	564-9842	567-9320	564-9842	564-9842
Price	\$	\$	\$	\$	\$	\$
Bracket 60 mm/60 mm, Pin On	N/A	N/A	564-9843	N/A	564-9843	564-9843
Price			\$		\$	\$
Bracket BHL-STD, Pin On, Tuck, LG	551-1546	551-1546	N/A	551-1546	N/A	N/A
Price	\$	\$		\$		
Bracket BHL- EXT, Pin On, Tuck, LG	565-3682	565-3682	N/A	565-3682	N/A	N/A
Price	\$	\$		\$		
Bracket BHL, QC, Pin On, Tuck, LG	572-6066	572-6066	N/A	572-6066	N/A	N/A
Price	\$	\$		\$		

### HAMMER LINES

MODEL	B6	B8	B9	H65s	H80s	H95s
Lines, BHL	570-6298	570-6298	532-9282	313-4791	399-6962	399-6962
Price	\$	\$	\$	\$	\$	\$
Lines BHL - Tuck	565-6083	565-6083	N/A	N/A	N/A	N/A
Price	\$	\$				
Lines BHL - QC	N/A	N/A	N/A	N/A	399-6964	399-6964
Price					\$	\$
Lines BHL - 450	N/A	N/A	532-9282	N/A	399-6964	399-6964
Price			\$		\$	\$

### HAMMER - BRACKET PINS

MODEL	B6	B8	B9	H65s	H80s	H95s
Pins, BHL-F (45 mm/50 mm)	178-3593	178-3593	178-3593	178-3593	178-3593	N/A
Price	\$	\$	\$	\$	\$	
Pins, BHL-F (60 mm/60 mm)	N/A	N/A	556-3635	N/A	556-3635	556-3635
Price			\$		\$	\$

Cat cold planers are designed for small paving jobs in residential and commercial applications and are primarily used to economically restore asphalt and concrete surfaces. Designed with a high speed drum and conical bits to quickly remove asphalt and concrete. They are ideal for milling imperfections prior to resurfacing, removing deteriorated pavement, removing traffic lane stripes and jobs where the use of dedicated planers is limited.



### COLD PLANERS

COLD PLANERS		PIN ON
MODEL	PC404	
Machine	415-444	
Working Width - in (mm)	18 (450)	
Overall Width - in (mm)	33 (828)	
Overall Length - in (mm)	37 (950)	
Overall Height - in (mm)	41 (1030)	
Max Cutting Depth - in (mm)	5 (125)	
Required Hydraulics	Rear Aux	
Weight - lb (kg)	1499 (680)	
Part Number	219-5470	
Price	\$	
Pins Group - Mounting	178-3593	
Price	\$	



# BACKHOE LOADER ATTACHMENTS

2021

Cat compaction wheels provide a low cost option for trench compaction. The wheels feature tapered roller bearings and tampered foot design for smooth operation. Six to ten passes are usually adequate to achieve compaction in normal soil conditions, dependent on the required compaction levels.

Pin on compaction wheels can be used in combination with applicable pin grabber quick coupler.



**COMPACTION WHEELS**

<b>COMPACTION WHEELS - 415-444</b>		<b>PIN ON</b>	
<b>Model</b>	<b>12 in</b>	<b>18 in</b>	<b>24 in</b>
Overall Width - in (mm)	16.6 (424)	17.2 (439)	22 (559)
Compaction Width - in (mm)	11.3 (286)	17.2 (439)	22 (559)
Overall Height - in (mm)	44.8 (1138)	43.8 (1112)	43.7 (1110)
Overall Length - in (mm)	39.2 (995)	39 (991)	39 (991)
Weight - lb (kg)	873 (396)	1108 (503)	1179(535)
Number of Wheels	2	3	3
Number of Pads	18	27	37
Part Number	517-6992	517-6993	517-6994
Price	\$	\$	\$



# BACKHOE LOADER ATTACHMENTS

2021

Built to cut through dense dirt, loosen rocky soil and break below the frost layer, Cat rippers are taking on some of the most challenging ground conditions. And because they are made for specific Cat models, they can better transfer machine power into ripping power.

RIPPERS	PIN ON
Machine	415-444
Shank Length - in (mm)	25 (639)
Overall Length - in (mm)	33 (833)
Width - in (mm)	17 (420)
Tip Radius - in (mm)	32 (806)
Weight - lb (kg)	240 (109)
Part Number	491-4075
Price	\$



Cat vibratory plate compactors provide superior compaction force in a reliable, low-maintenance package. These units produce high-power impulses at a rate of 2200 impacts per minute. The forces generated by this vibration drive soil particles close together for solid, stable compactions. Whether in a trench or on a slope, driving sheeting or posts, Cat compactors are the superior choice for any jobsite's compaction tasks.



**VIBRATORY PLATE COMPACTOR**

VIBRATORY PLATE COMPACTOR	
MODEL	CVP40
Base Plate Width - in (mm)	23 (590)
Compaction Area - ft2 (mm2)	6.1 (0.57)
Base Plate Length - in (mm)	38 (965)
Required Hydraulics	Rear Aux
Weight - lb (kg)	886 (402)
Part Number	551-4957
Price	\$
Lines Gp - BHL-F (415-444)	491-7486
Price	\$
Lines Gp - BHL-F (450)	
Price	\$
Kit - Thumb Stop*	311-2600
Price	\$

\* FOR USE WITH: 415-440 D, E, F and Next Gen machines when fitted with pin grabber quick coupler, a thumb arrangement and CVP40 compactor. Needed to protect hydraulic hoses from crushing.

# BACKHOE LOADER ATTACHMENTS

2021



**BRACKETS**

## PLATE COMPACTOR BRACKETS

Bracket 45 mm/50 mm, Pin On, XL	564-9842
Price	\$
Bracket 60 mm/60 mm, Pin On, XL	564-9843
Price	\$
Bracket 1/4 yd Pin Lock, XL	416-8031
Price	\$
Bracket 1/2 yd Pin Lock, XL	564-2732
Price	\$



**BACKFILL BLADE**

## PLATE COMPACTOR BACKFILL BLADES

Backfill Blade	211-8200
Price	\$



**SWIVEL HEADS**

## PLATE COMPACTOR SWIVEL HEADS

Swivel Head, XL to XL	264-5907
Price	\$
Swivel Head, Pin On, BHL to XL*	311-2599
Price	\$

\* FOR USE WITH: CVP40 and 415-440 D, E, F and Next Gen machines - swivel and bracket combined.



